



Manhole Products

**54" Type 2 Precast Catch Basin
WSDOT B-10.20-03**

Square Risers Available

- 2", 3", 4", 6", 12", 24" Solid or w/ Knockouts

Grade Adjustment Rings Available

- 2", 3", 4", 6"

Hole or Knock Out Dimensions

- Maximum hole size is 42 inches
- 8 inches of minimum distance between holes
- 2 inch diameter lifting holes provide
- Cored, cast-in and custom block-out/knock-outs available

Conformity Standards

- ASTM C478 Manhole
- ASTM C443 rubber gasket joint
- ASTM D4101 polypropylene steps and ladders
- Washington State APWA / WSDOT Standard

Options Available

- 2 foot minimum sump
- Specialized coatings
- Custom hatches
- Kor-N-Seal boots
- 1' thru 10' Polypropylene ladders
- Round offset & center hole flat tops
- Mastic

Section Specifications

Height	Section	Base
6"	502 LBS	2,185 LBS
12"	1,056 LBS	2,739 LBS
24"	2,138 LBS	3,821 LBS
36"	3,221 LBS	4,904 LBS
48"	4,305 LBS	5,988 LBS
60"	5,388 LBS	7,071 LBS
72"	6,254 LBS	7,937 LBS

Base Slab	Flat Top
2,145 LBS	2,114 LBS

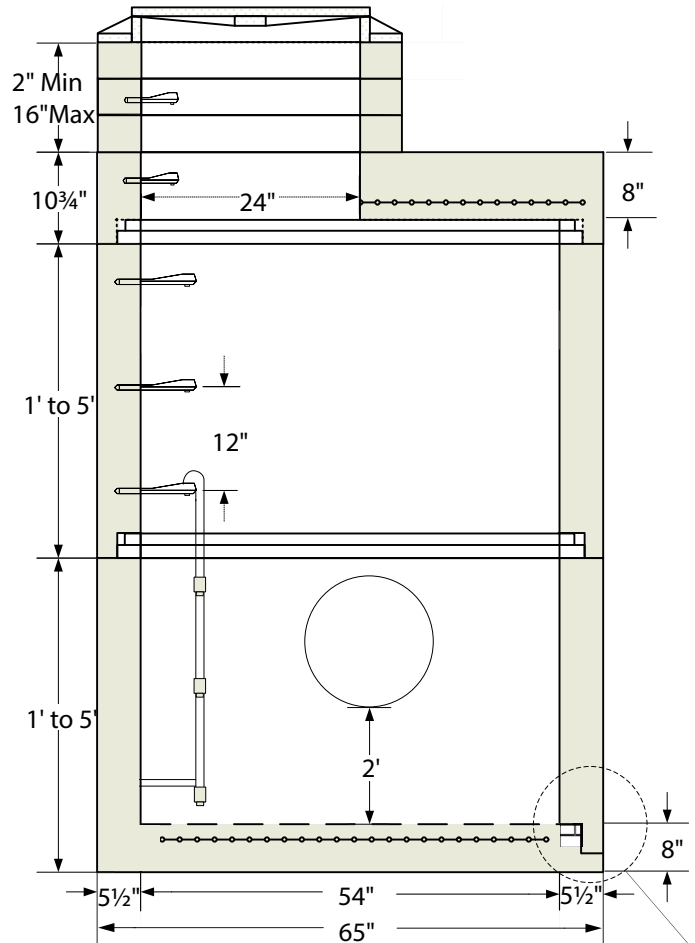

Top Slab Plan View

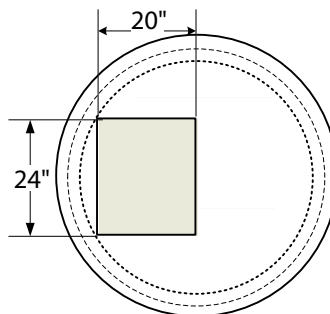

Gasket Shown Uncompressed

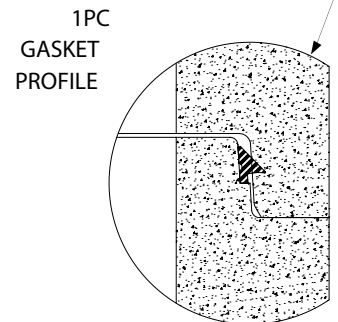

Note: Drawings not to scale

www.shopeconcrete.com

1-800-422-7560 [TOLL FREE]



Shope Concrete, LLC
1618 East Main Avenue
Puyallup, WA 98372-3142

(253) 848-1551
Fax Line 1 (253) 845-0292
Fax Line 2 (253) 864-6172

